

Putzmeister

Stationary concrete pump

BSA 1407 D

Output up to 71 m³/h
Delivery pressure up to 106 bar

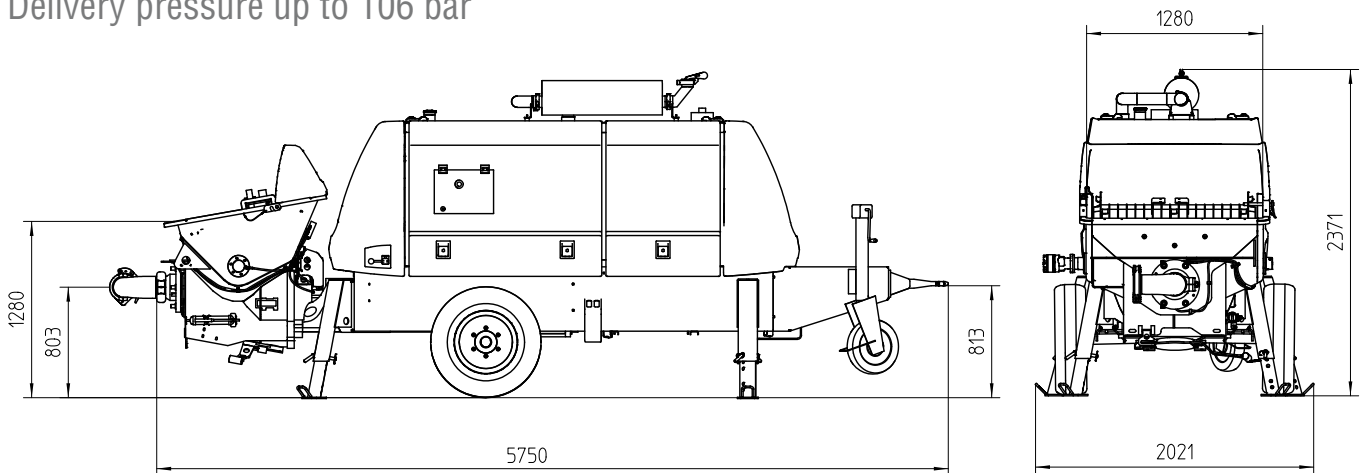

Note: Standard version. Dimensions and weights depend on equipment. Subject to technical modifications and errors.

Technical data

Model		BSA 1407 D
Material number		102340.000
Output	m ³ /h	71 / 47 *
Delivery pressure	bar	71 / 106 *
Delivery cylinder	Ø mm	200
Delivery cyl. stroke	mm	1400
Strokes / minute		27 / 18 *
Engine power	kW	115
Hopper		RS 909
Capacity	l	approx. 600
Filling height	m	1.3
Transfer tube		S 2015 D
Line connection	mm	SK 125
Pressure connection	"	5.5
Control system		SPC-OPS
Weight	kg	4300

* Values for hydraulic fluid being fed to piston-side
All data maximum theoretical

Serial equipment

Agitator safety switch off	Operating manuals (1× paper, 1× CD-ROM) spare part list
Cable remote control 10 m	Outriggers 4× mech.
Central lubrication on hopper with hand lever press	Reduction bend 90°; SK 150 → SK 125
Cleaning accessories	Splash guard
Coloring: Pump, frame, roof, tank and hood anthracite-grey Cover chrome yellow	Speed drawdown automatically on pump stop
Concrete hopper with agitator	Support wheel
Coupling ring (DIN)	Tool set incl. standard equipment
Drive diesel, Deutz 115 kW	Trailer F8, travelling in site
Electronic error management	
Ergonic Graphic Display (EGD)	
Flushing water pump 50 l/min 20 bar	
Gate valve connection	
Grill 70 mm	

See quotation for exact serial delivery scope.
Comprehensive range of options available on request.