

**Putzmeister**

# Truck-mounted concrete pump BSF 42-5.16 H

**.16 H LS**

Output up to 160 m<sup>3</sup>/h  
Delivery pressure up to 85 bar\*

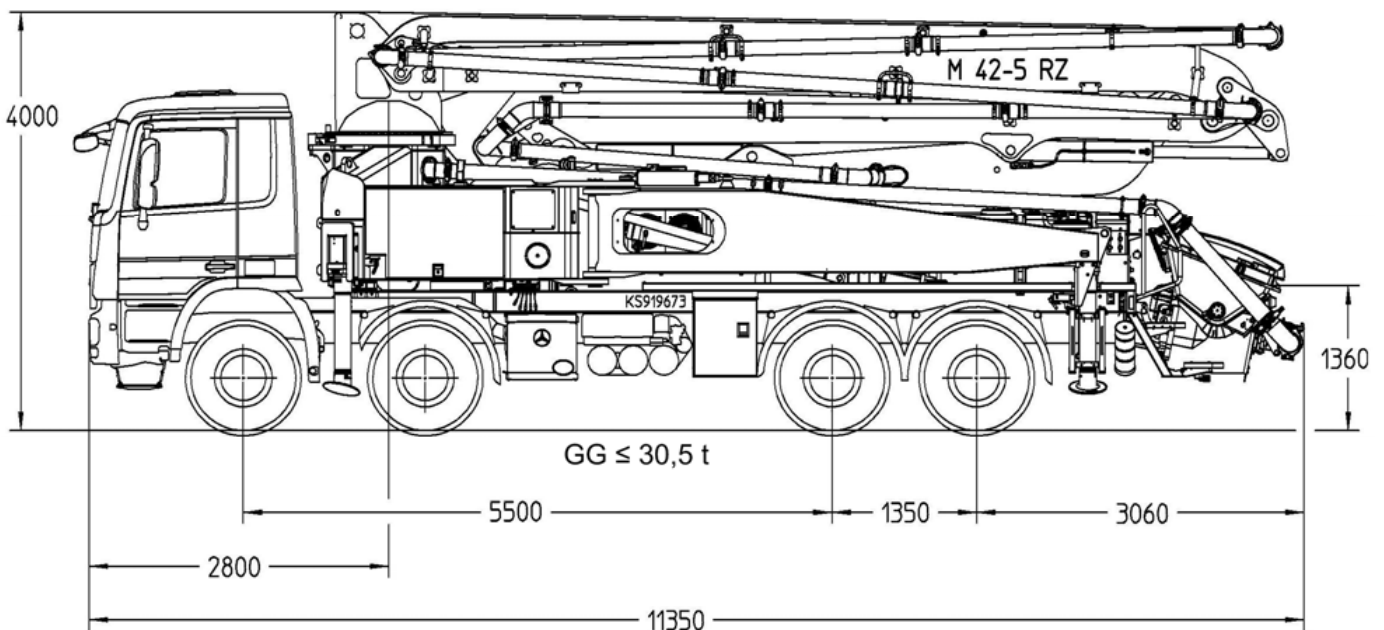
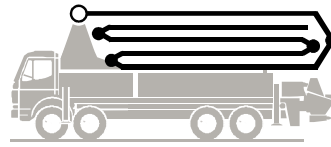

Note: Standard version. Dimensions and weights depend on truck, pump model and equipment.  
Dimensions in mm, MB-Actros 3241, Euro 5 as example.

## Technical data

Boom M 42-5		
Sections		5
Reach height	m	41.6
Horizontal reach	gross	m 37.3
	net	m 34.5
Reach depth max.	m	31.0
Unfolding height	m	8.6
End hose length	m	4
Folding system		RZ
Delivery line		DN 125

Pump		BSF	.16 H	.16H LS
Rod side	Output	m <sup>3</sup> /h	160	-
	Delivery pressure	bar	85	-
	Strokes	1/min.	31	-
Piston side	Output	m <sup>3</sup> /h	-	160
	Delivery pressure	bar	-	85
	Strokes	1/min.	-	26
	Delivery cylinder	Ø mm	230	250
	Stroke	mm	2100	2100

\*) Delivery line boom max. 85 bar.  
All data maximum theoretical.

# Reach information diagram, Support, Performance diagram

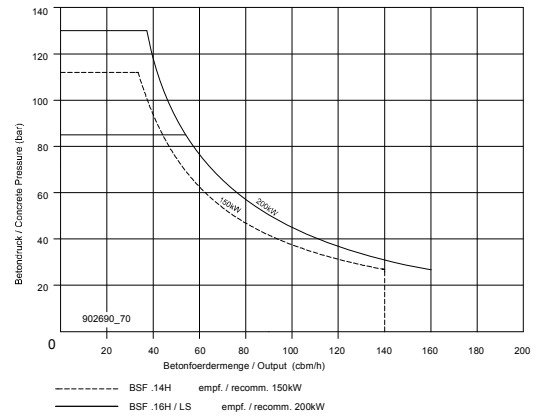
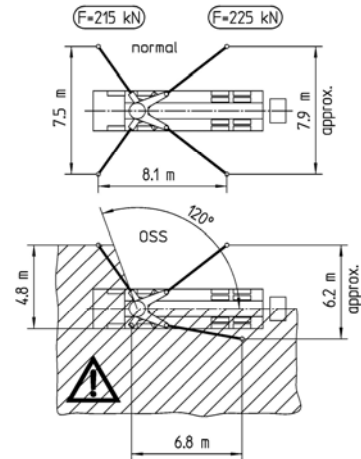
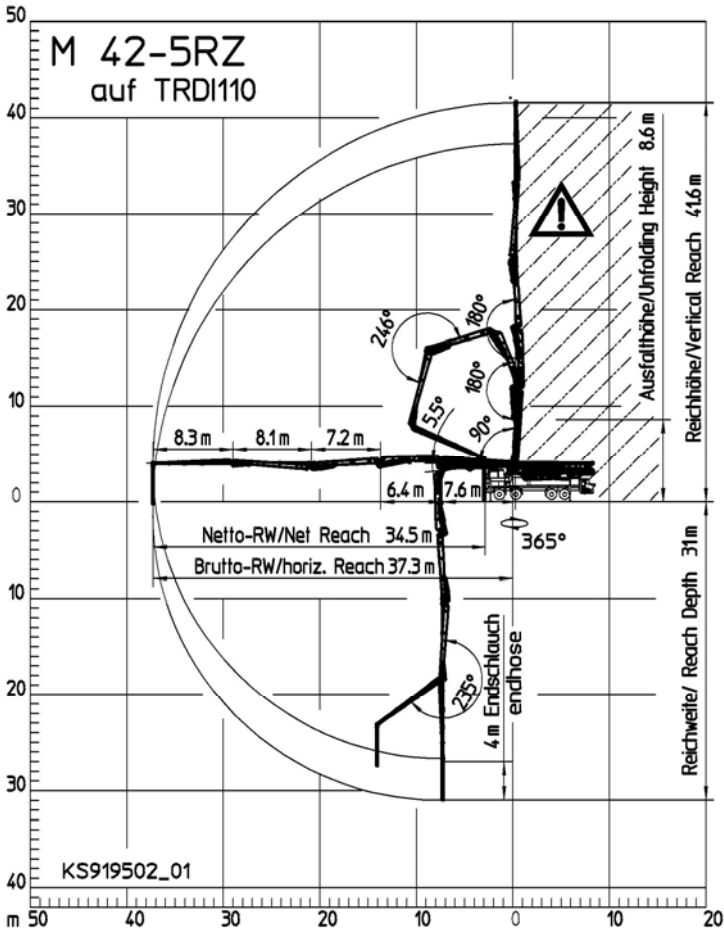

All data max. theor.



Range in which you must not work with the end hose.

## Serial delivery scope

Agitator and water pump radio remote / on-site controlled	Diagnose interface	Remote control with 40 m cable, without display
Agitator safety cutout (RSA) in RFID with self-start protection	End hose 4,0 m DN 125	Rubber collar at hopper
Box for delivery slip	Ergonic Graphic Display (EGD) with machine-fault-management	Spectacle wear plate DURO 22
Box for sponge balls	Ergonic Pump System (EPS) incl. Ergonic Output Control (EOC)	Splash guard fixed
C-pipe connection for filling water tank	Flushing water pump 160 l/min, 25 bar	Spray hose 10 m incl. bracket
Cardan shaft maintenance free	Handrail left/right	Storage box, plastic, black
Central lubrication hopper, electrically	Hinged elbow with cleaning port	S-transfer tube switchover normal/fast
Cleaning port with sliding pin	Chassis horn, yellow button at hopper	Supportplates at slewing leg in holder
Concrete hopper RS 909 with agitator	Hydraulic spare hose in hose-package	Toolset incl. standard equipment
Connections for hydraulic emergency supply	Operating manual certified	Towing eye
Delivery cylinder, chrome-plated	Oscillating support plates	Wateroutlet for small amounts at hopper (1/2")
Delivery line (1-layer) PM 40, arm assembly	Platform non-skid	Watertank 800 l
Delivery piston "compact" (14 H, 16 H), "single" (16 H LS)	Radio remote control proportional with display	Working light for lightening of hopper
	Rearsteps foldable	

See quotation for exact serial delivery scope.  
Comprehensive range of options available on request.